



REPLY TO  
ATTENTION OF

DEPARTMENT OF THE ARMY  
THE INSTITUTE OF HERALDRY  
9325 GUNSTON ROAD, ROOM S112  
FORT BELVOIR, VIRGINIA 22060-5579

AAHS-IHS (840-10a)

MAR 5 2015

MEMORANDUM FOR Commander, 82d Airborne Division Sustainment Brigade, ATTN:  
Brigade S1 (CPT Wimmer), Building 4568 Waal Street, Fort Bragg, NC 28310

SUBJECT: Beret Flash and Background Trimming for the 82d Airborne Division  
Sustainment Brigade

1. The request for a beret flash and background trimming for the 82d Airborne Division Sustainment Brigade is approved. Forwarded for your organizational records is the authorization letter (encl 1).
2. Also enclosed for use in procurement of the items are:
  - a. Manufacturing drawings for the flash and trimming (TIOH Dwg. No. A-4-300 and A-6-327) (encls 2 and 3).
  - b. Color prints and black and white line drawings of the flash and trimming (encls 4 and 5).
  - c. A list of certified manufacturers and procedures for local procurement of insignia (encls 6 and 7).
3. POC this Institute is Mrs. Henning by telephone at DSN 656-4972, Commercial (703) 806-4972 or by email at [Bonnie.s.henning.civ@mail.mil](mailto:Bonnie.s.henning.civ@mail.mil).

7 Encls  
as

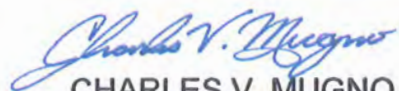
  
CHARLES V. MUGNO  
Director



REPLY TO  
ATTENTION OF

DEPARTMENT OF THE ARMY  
THE INSTITUTE OF HERALDRY  
9325 GUNSTON ROAD, ROOM S112  
FORT BELVOIR, VIRGINIA 22060-5579

AAHS-IHS (840-10a)

MAR 25 2015

MEMORANDUM FOR Commander, 82d Airborne Division Sustainment Brigade, ATTN:  
Brigade S1 (CPT Wimmer), Building 4568 Waal Street, Fort Bragg, NC 28310

SUBJECT: Beret Flash and Background Trimming for the 82d Airborne Division  
Sustainment Brigade

1. In accordance with the provisions of AR-670-1, a beret flash and background trimming are authorized for wear by members of the 82d Airborne Division Sustainment Brigade
2. The descriptions of the designs are as follows:

#### BERET FLASH

A shield-shaped embroidered item with a semi-circular base 2 1/4 inches (5.72 cm) in height and 1 7/8 inches (4.76 cm) in width overall, diagonally divided from upper right vertex to lower left, blue to the left and soldier red to the right, surmounted on the division line by a white lightning bolt; all within a 1/8 inch (.32 cm) blue border.

#### BACKGROUND TRIMMING

An oval-shaped embroidered item 1 3/8 inches (3.49 cm) in height and 2 1/4 inches (5.72 cm) in width overall, diagonally divided from upper right vertex to lower left, blue to the left and soldier red to the right, surmounted on the division line by a white lightning bolt; all within a 1/8 inch (.32 cm) blue border.

#### CABLE NUMBERS OF COLORS

Soldier Red	#67157
Ultramarine Blue	#67118
White	#67101

AAHS-IHS (840-10a)

SUBJECT: Beret Flash and Background Trimming for the 82d Airborne Division Sustainment Brigade

3. This authorization does not grant exclusive use of the above colors and pattern design for the 82d Airborne Division Sustainment Brigade.



CHARLES V. MUGNO  
Director

CF: CMH

**REVISIONS**

LTR	DESCRIPTION	DATE	APPROVED
-----	-------------	------	----------

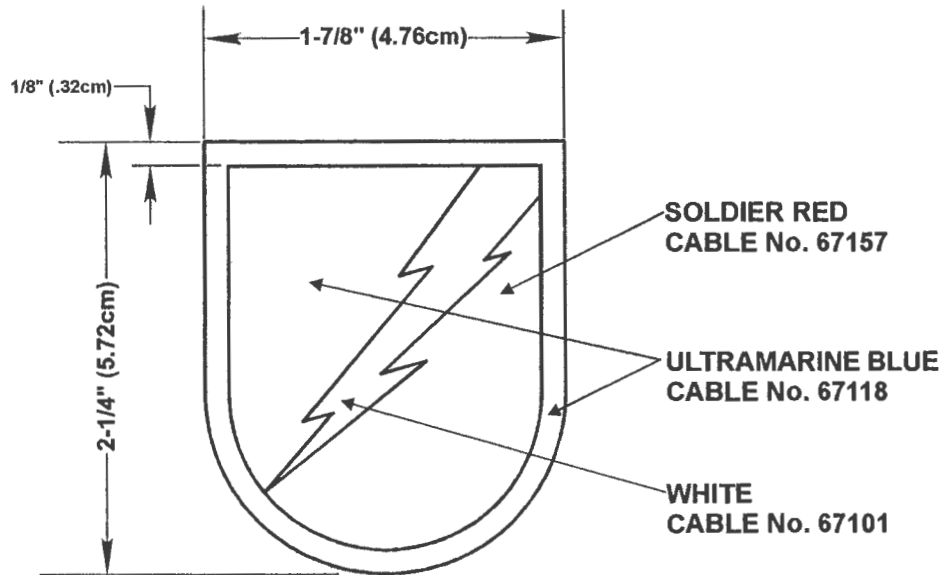

**DESIGNED FOR OVEREDGE STITCHING**

UNLESS OTHERWISE SPECIFIED DIMENSIONS ARE IN INCHES TOLERANCES ON FRACTIONS DECIMALS ANGLES

**THE INSTITUTE OF HERALDRY, DEPARTMENT OF THE ARMY**

9325 GUNSTON RD, RM S-113 FORT BELVOIR, VA 22060-5579

EXAMINED	<i>SAO</i>	
CHECKED	<i>CA</i>	
PREPARED	<i>CA</i>	

**BERET FLASH FOR**

**82D ABN SUSTAINMENT  
BRIGADE**

**MATERIALS:**  
TO BE MANUFACTURED IN ACCORDANCE WITH MIL-DTL-14652

APPROVED  
*Charles V. Mugno*  
CHARLES V. MUGNO  
DIRECTOR

SIZE CONTROL IDENT. NO

**A 22571**

**A-4-300**

SCALE FULL DATE

**18 MARCH 2015**

**REVISIONS**

LTR	DESCRIPTION	DATE	APPROVED
-----	-------------	------	----------

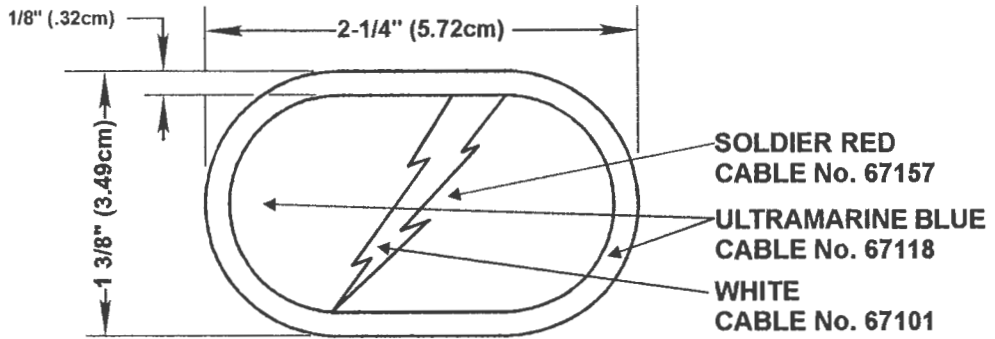

**DESIGNED FOR OVEREDGE STITCHING**

UNLESS OTHERWISE SPECIFIED DIMENSIONS ARE IN INCHES TOLERANCES ON FRACTIONS DECIMALS ANGLES

EXAMINED	<i>SAD</i>	
CHECKED	<i>CA</i>	
PREPARED	<i>CA</i>	

THE INSTITUTE OF HERALDRY, DEPARTMENT OF THE ARMY  
9325 GUNSTON RD, RM S-113 FORT BELVOIR, VA 22060-5579

**BACKGROUND TRIMMING FOR  
82D ABN SUSTAINMENT  
BRIGADE**

MATERIALS:  
TO BE MANUFACTURED IN ACCORDANCE WITH MIL-DTL-14652

APPROVED  
*Charles V. Mugno*  
CHARLES V. MUGNO  
DIRECTOR

SIZE CONTROL IDENT. NO

**A 22571**

**A-6-327**

SCALE FULL DATE

**24 MARCH 2015**



**FLASH**



**TRIM**

**FLASH and TRIM  
82D AIRBORNE DIVISION**

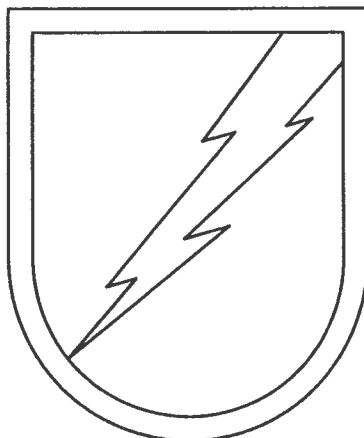

**FLASH**

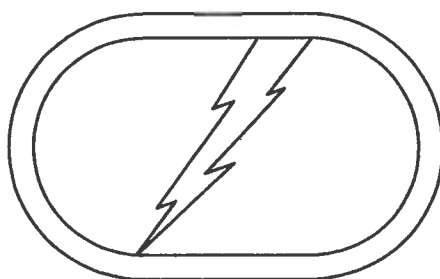

**TRIM**

**FLASH and TRIM  
82D AIRBORNE DIVISION**